

Addendum to HPCN User's Guide: Quick-Start Guide

This quick-start guide explains how to prepare the High-Performance Computing Platform-Net (HPCN) evaluation board, connect it to a host system, and boot Linux. For more information and details about the platform, consult the HPCN user's guide, entitled *HPCN—A High-Performance, Low-Profile Networking Server System* (order no. HPCNUG).

Contents	
1. Connecting HPCN	1
2. Power-Up and Log-On	3
3. What's Inside	4

1 Connecting HPCN

This section describes how to connect the HPCN system to the local host computer and configure terminal emulator software to communicate with HPCN.

[Figure 1](#) shows a rear view of the HPCN evaluation board chassis.

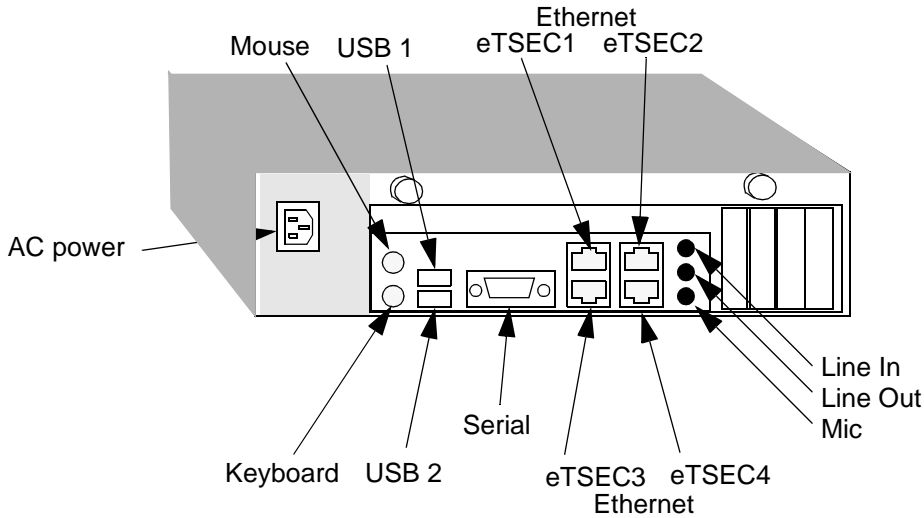

Figure 1. HPCN Evaluation Board Chassis—Rear View

1.1 Connect Ethernet, Serial, and Power Cables

1. Connect the AC power cable to the matching receptacle.
NOTE: If the power supply has a voltage select switch, make sure it is set to match local AC power line voltage (115 V @ 60 Hz, or 230V @ 50 Hz). Not all power supplies have one - if present, it will be near the AC power/mains connector.
2. Plug the power cord into a surge-protected power strip (recommended).
3. Connect the surge-protected power strip to an AC outlet.
4. Connect a 9-pin “null-modem” serial cable (included) between the HPCN serial connector and the host-computer serial port (any COM port compatible with the host-computer’s terminal emulator, typically COM1 or COM2)
5. If network capability is desired, connect Ethernet cable between Ethernet port “eTSEC1” and your local 10/100/1G-bit network or hub (the other Ethernet ports may also be used). The ports automatically adjust to the correct speed
6. If a Linux GUI (Graphical User Interface) is desired, attach a mouse and keyboard (not provided) to the legacy PS/2 ports or to the USB ports. Attach a video monitor to the slot-based video card (not provided).

1.2 Set Up Serial Communications with Host System

Using a terminal emulator (such as Terminal or PowerTerm on Linux, or HyperTerminal or SmartComm on Windows).

- Baud rate: 115,200 kbps
- Data bits: 8
- Parity: None
- Stop bits: 1
- Flow control: None
- Terminal Emulation: VT102/VT52

2 Power-Up and Log-On

2.1 Power Up System

Press the power button on the front panel. [Figure 2](#) shows a front view of the current HPCN evaluation board chassis.

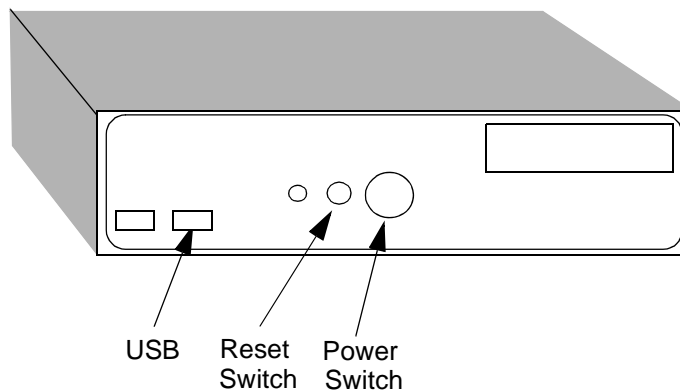

Figure 2. HPCN Evaluation Board Chassis—Front View

Note that the chassis market undergoes rapid obsolescence, so Freescale may substitute equivalent ATX/microATX chassis as needed.

2.2 Log On

1. When powered up, the system will automatically boot. By default, U-boot write several diagnostic messages to the serial port, and will automatically boot Linux after the system is setup.
NOTE: Early systems may require the reset switch to be manually pressed after power-up. If no messages are seen on the serial console after power-up, press the reset switch.
2. Wait for the system to boot (this may take a few minutes). The terminal will display numerous messages while booting.
3. If necessary, the boot process can be interrupted by pressing any key while U-boot is booting up. Booting can be resumed by executing the **boot** command at the U-boot prompt. If the Linux kernel has started booting, it cannot be interrupted.
4. At the login prompt, enter the user name 'root'. No password is required. (The same username and password are also used if connecting remotely via Ethernet.)
5. The Linux command prompt will appear, indicating that Linux has been successfully booted. If the command prompt does not occur, the system can be reset or powered down.

2.3 Powering Down

If Linux was booted, and in particular if the hard disk was used, a more graceful powerdown sequence is strongly recommended (as opposed to simply turning the power off). At the Linux console, enter the command:

```
shutdown -h now
```

If Linux was not booted, either due to a kernel panic or some sort of error; or if only U-boot or DINK were used, the system can be simply turned off or reset when needed.

2.4 Powering Off

To prevent accidental power-off of the system, the APM (advanced power management) function of the ULI M1575 defaults to requiring a 4 second duration of the power button.

To turn off the system, simply press the power button for 4 seconds.

3 What's Inside

This section describes how to open the case in order to verify factory default settings and change system hardware settings. To change system settings, or if the system does not appear to operate correctly, the case must be opened.

CAUTION: Always observe appropriate static precautions while performing the operations described in this section.

3.1 Open Case.

1. Power down the system by pressing the power button on the front panel for four seconds.
2. Disconnect the AC power cable.
3. Remove the two thumbscrews at the top of the rear panel; see [Figure 3](#).

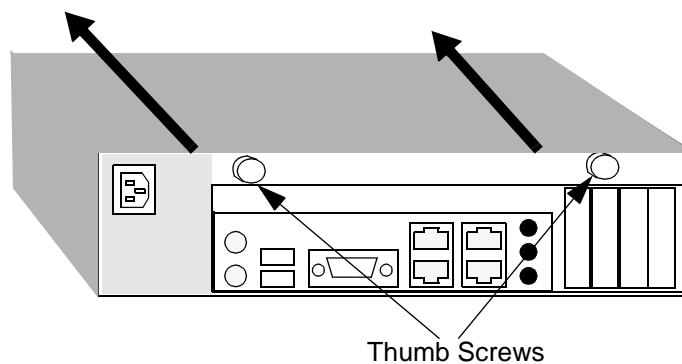

Figure 3. Removing the Cover—Rear View

5. Grasping each side of the case, slide the top of the case forward, then lift and remove the top cover. [Figure 4](#) is a diagram of the HPCN evaluation board.

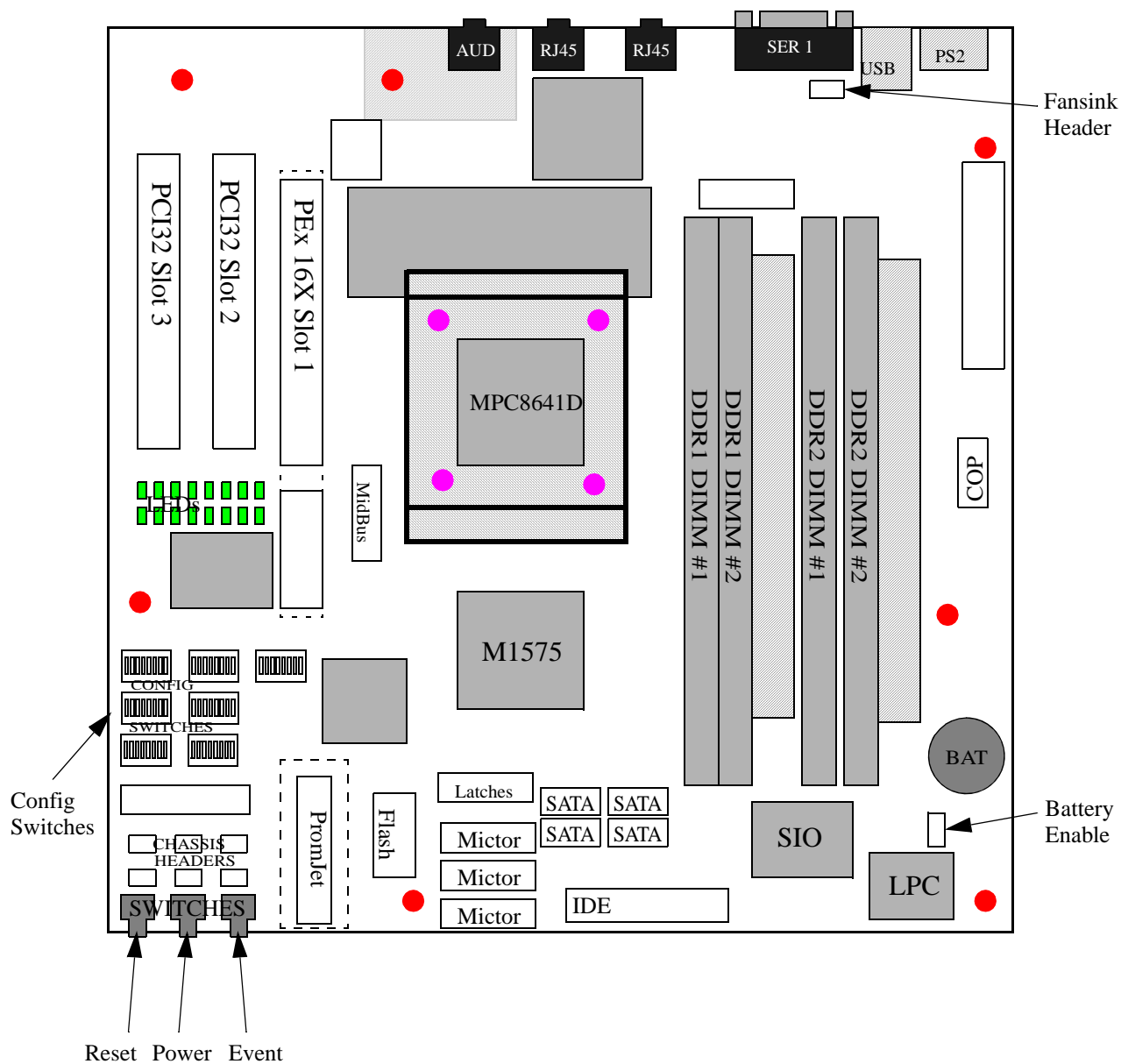

Figure 4. HPCN Evaluation Board Diagram

3.2 Confirm Factory Settings for Jumper Headers

1. Verify that a jumper is installed in “Battery Enable” header J14, across pins 1-2 (those closest to the battery).

What's Inside

2. Verify that CPU fansink power cable is connected to the Fansink Power Header.
3. Verify that chassis power switch is connected to header J18.
4. Verify that chassis reset switch is connected to header J16.

3.3 Verify and/or Change Configuration Switch Settings

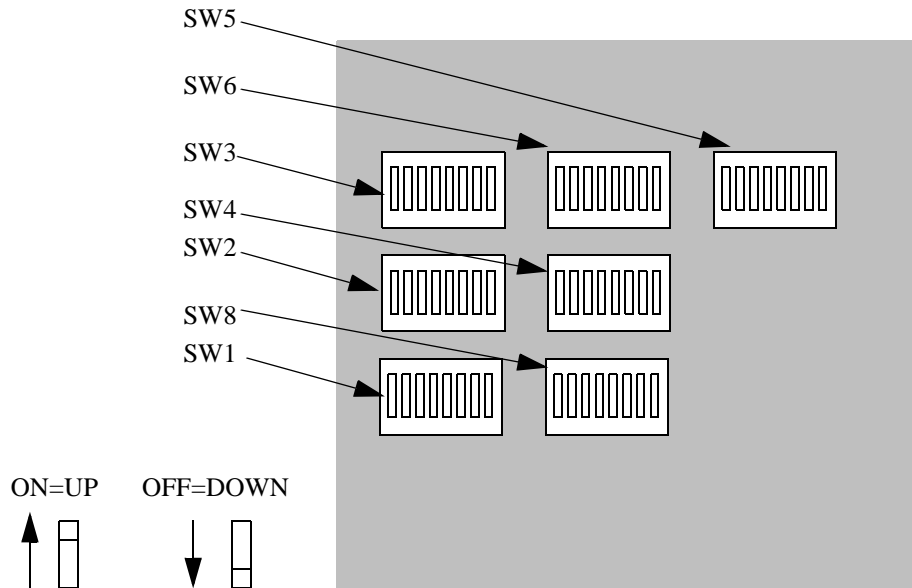

Switch functions and default settings are provided in the HPCN Design Workbook, entitled *HPCN—A High-Performance, Low-Profile Server System* (order no. HPCNUG). The following are some typical examples of settings or modes that may be desired:

1. Boot DINK32 instead of U-boot/Linux
Set SW5-1 (SW5, position 1) to OFF.

CAUTION: Some switch settings, especially those controlling CPU core voltage and frequency, may cause unreliable operation and/or device damage. Consult the HPCN Design Workbook before changing any other switch settings from their factory default positions.

THIS PAGE INTENTIONALLY LEFT BLANK

How to Reach Us:

USA/Europe/Locations Not Listed:

Freescale Semiconductor
Literature Distribution Center
P.O. Box 5405,
Denver, Colorado 80217
1-480-768-2130
(800) 521-6274

Japan:

Freescale Semiconductor Japan Ltd.
Technical Information Center
3-20-1, Minami-Azabu, Minato-ku
Tokyo 106-8573, Japan
81-3-3440-3569

Asia/Pacific:

Freescale Semiconductor Hong Kong Ltd.
2 Dai King Street
Tai Po Industrial Estate
Tai Po, N.T. Hong Kong
852-26668334

Home Page:

www.freescale.com

Information in this document is provided solely to enable system and software implementers to use Freescale Semiconductor products. There are no express or implied copyright licenses granted hereunder to design or fabricate any integrated circuits or integrated circuits based on the information in this document.

Freescale Semiconductor reserves the right to make changes without further notice to any products herein. Freescale Semiconductor makes no warranty, representation or guarantee regarding the suitability of its products for any particular purpose, nor does Freescale Semiconductor assume any liability arising out of the application or use of any product or circuit, and specifically disclaims any and all liability, including without limitation consequential or incidental damages. "Typical" parameters which may be provided in Freescale Semiconductor data sheets and/or specifications can and do vary in different applications and actual performance may vary over time. All operating parameters, including "Typicals" must be validated for each customer application by customer's technical experts. Freescale Semiconductor does not convey any license under its patent rights nor the rights of others. Freescale Semiconductor products are not designed, intended, or authorized for use as components in systems intended for surgical implant into the body, or other applications intended to support or sustain life, or for any other application in which the failure of the Freescale Semiconductor product could create a situation where personal injury or death may occur. Should Buyer purchase or use Freescale Semiconductor products for any such unintended or unauthorized application, Buyer shall indemnify and hold Freescale Semiconductor and its officers, employees, subsidiaries, affiliates, and distributors harmless against all claims, costs, damages, and expenses, and reasonable attorney fees arising out of, directly or indirectly, any claim of personal injury or death associated with such unintended or unauthorized use, even if such claim alleges that Freescale Semiconductor was negligent regarding the design or manufacture of the part

Learn More: For more information about Freescale Semiconductor products, please visit www.freescale.com

Freescale™ and the Freescale logo are trademarks of Freescale Semiconductor, Inc. [The PowerPC name is a trademark of IBM Corp. and is used under license.](#) All other product or service names are the property of their respective owners.

© Freescale Semiconductor, Inc. 2006.

HPCNQS
Rev. 0.3
7/2006

